

SHEET: 1/1

2915 ASSEMBLY

SCALE: 1/1

NO	REV.NO	DATE	MATERIAL:	TOLERANCES	G
1	###	dd.mm.yy	DRAFT: MESUT EFE	0.00/25.00	±0.10
2	###	dd.mm.yy	DESIGN: MESUT EFE	25.01/100.00	±0.20
3	###	dd.mm.yy	CHECK: AYDIN AYTEKİN	100.01/250.00	±0.30
4	###	dd.mm.yy	APPR.: AYDIN AYTEKİN	250.01/1000.00	±0.60
5	###	dd.mm.yy	VESTEL ELEKTRONİK SAN. VE TİC. A.Ş. MANİSA / TÜRKİYE	1000.01/2500.00	±1.00
6	###	dd.mm.yy	TEL: +90.236.2330131 FAX: +90.236.2333868 MAIL: MESUT.EFE@vestel.com.tr	ANGLES	±0.25°

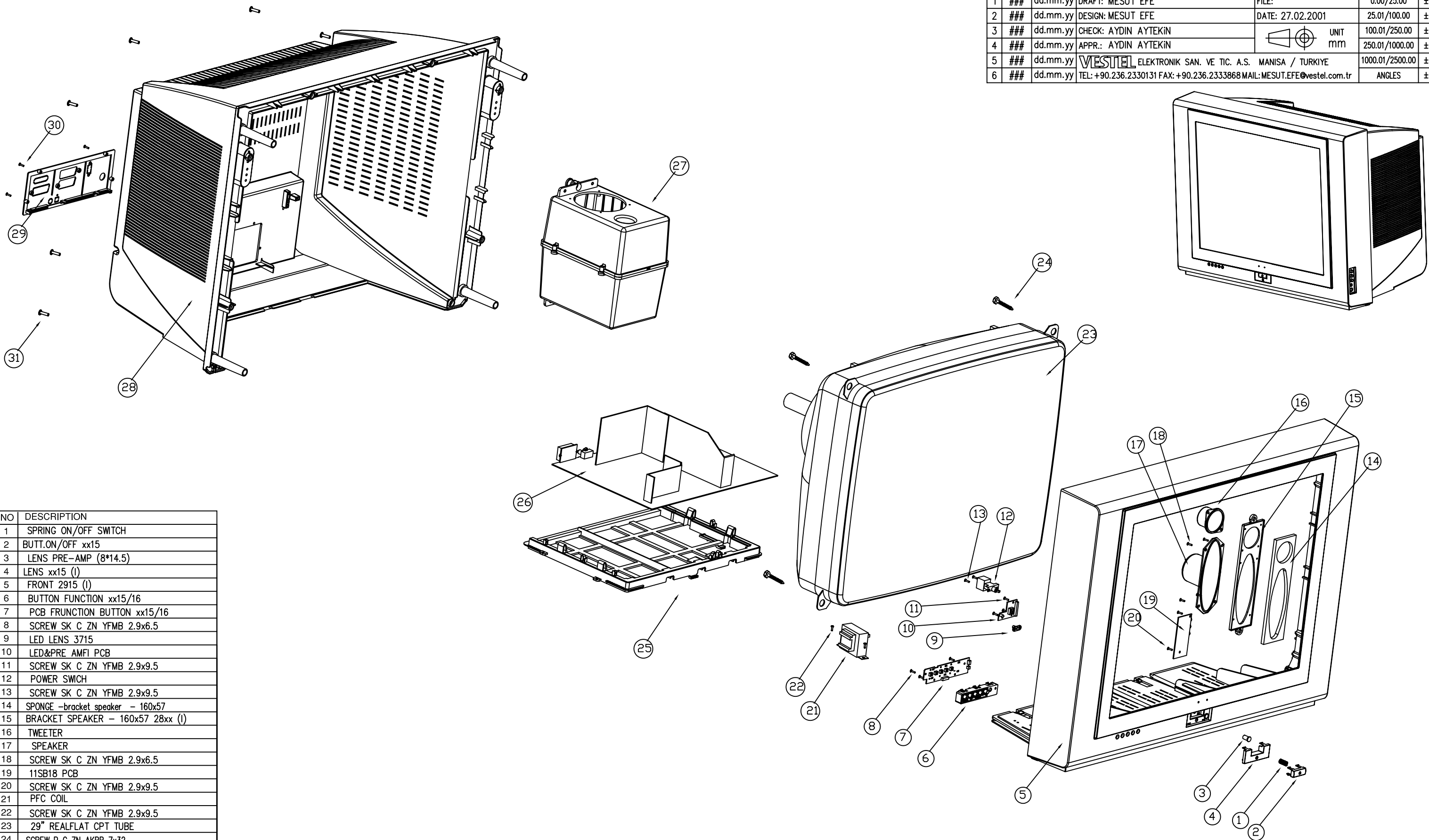

NO	DESCRIPTION
1	SPRING ON/OFF SWITCH
2	BUTT.ON/OFF xx15
3	LENS PRE-AMP (8*14.5)
4	LENS xx15 (l)
5	FRONT 2915 (l)
6	BUTTON FUNCTION xx15/16
7	PCB FRUNCTION BUTTON xx15/16
8	SCREW SK C ZN YFMB 2.9x6.5
9	LED LENS 3715
10	LED&PRE AMFI PCB
11	SCREW SK C ZN YFMB 2.9x9.5
12	POWER SWICH
13	SCREW SK C ZN YFMB 2.9x9.5
14	SPONGE -bracket speaker - 160x57
15	BRACKET SPEAKER - 160x57 28xx (l)
16	TWEETER
17	SPEAKER
18	SCREW SK C ZN YFMB 2.9x6.5
19	11SB18 PCB
20	SCREW SK C ZN YFMB 2.9x9.5
21	PFC COIL
22	SCREW SK C ZN YFMB 2.9x9.5
23	29" REALFLAT CPT TUBE
24	SCREW P C ZN AKBR 7x32
25	BRACKET CHASSY 288X (AK33)
26	CHASSIS
27	SUBWOOFER
28	BACK CVR. 2915/16 (l)
29	BACK DOOR
30	SCREW S C ZN YSMB 3.9*6.5
31	SCREW P C SYF YSB 4x20